



Before assembly

- We recommend that time is taken to read the instructions before starting assembly, then follow the easy step by step guide. The instruction sheet is only a guide to the assembly. Certain items may not be shown to scale.
- Check all components prior to assembly
- This product should be assembled by no less than 2 people.
- Never attempt to erect the assembly in high winds.
- Drill components where indicated.



Recommended tools for assembly

- Cross head screw driver
- Drill with 4mm diameter drill bit
- Tape measure
- Step ladder

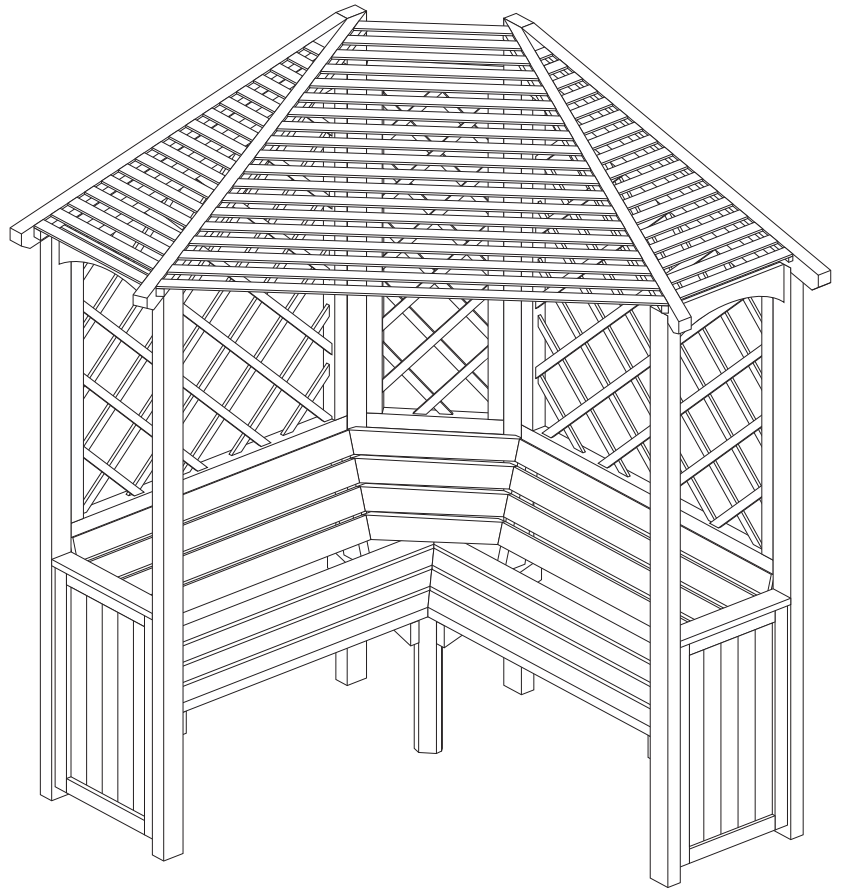

No.	Components	Qty.
1	Uprights	2
2	Left-hand seat	1
3	Right-hand seat	1
4	Back rest	2
5	Lattice	2
6	Back legs	2
7	Corner back rest slat (350mm)	1
8	Corner back rest slat (380mm)	1
9	Corner back rest slat (410mm)	1
10	Corner back rest slat (435mm)	1
11	Centre seat support	1
12	Corner lattice	1
13	Outer rafters	2
14	Left-hand inner rafter	1
15	Right-hand inner rafter	1
16	Left-hand roof section	1
17	Right-hand Roof section	1
18	Top centre roof section	1
19	Bottom centre roof section	1

No.	Fixing kit	Qty.
20	100mm screws	4
21	70mm screws	12
22	60mm screws	48
23	40mm screws	20

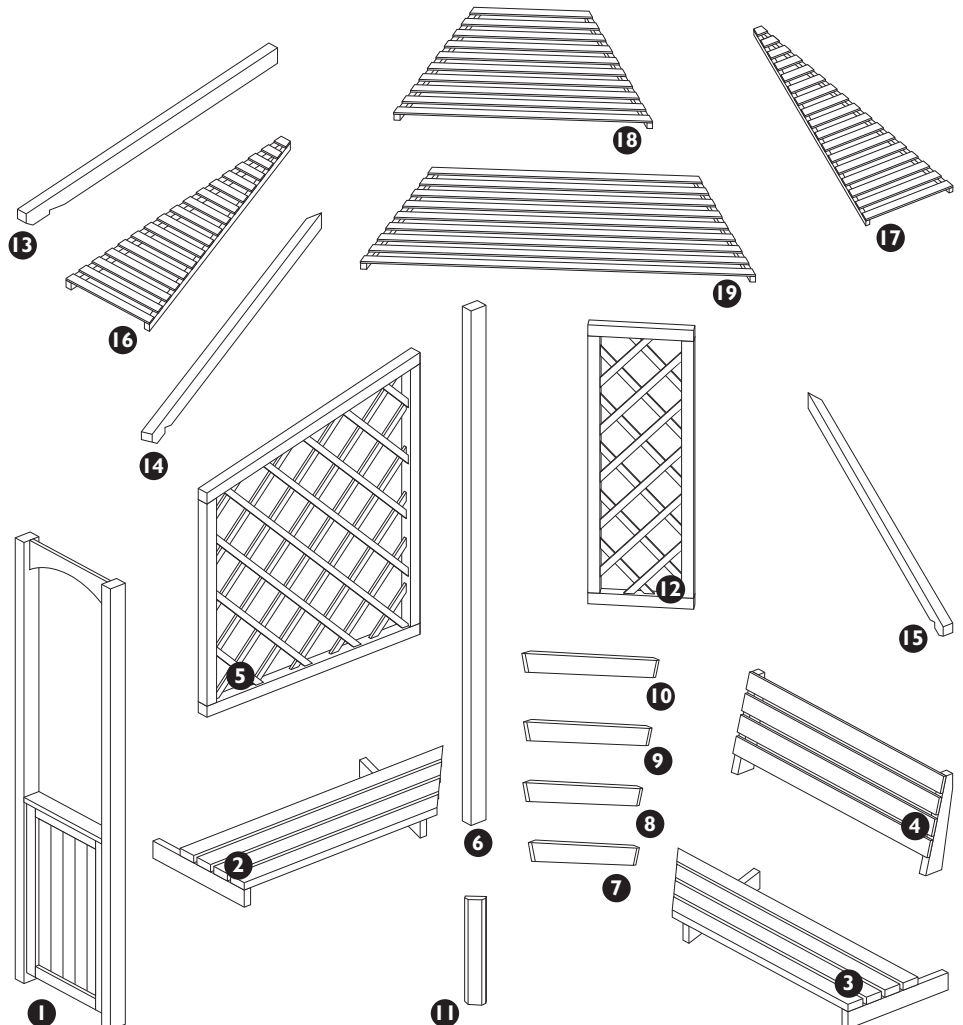

1. Seats to uprights

Drill pilot holes in the seat slat bearers as shown. Lay the upright on the ground and position the top of the seat bearer 420mm from the bottom of the upright. Secure the seat to the legs of the upright using 4 x 60mm screws. Screw through the drilled holes in the seat bearers into the upright legs.



Drill

Drill pilot holes in the seat bearers for each screw.

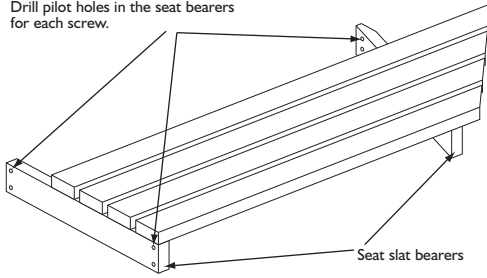

Note:

To make assembly easier, lay the upright on the ground.

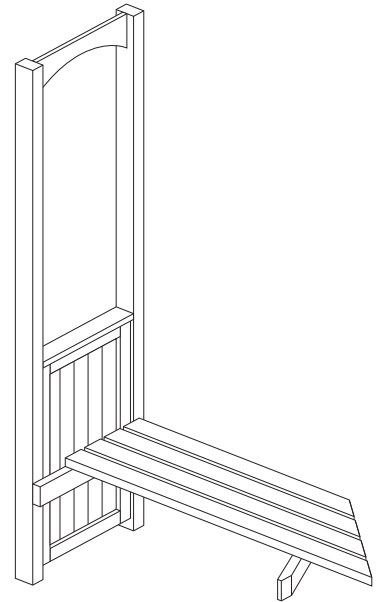
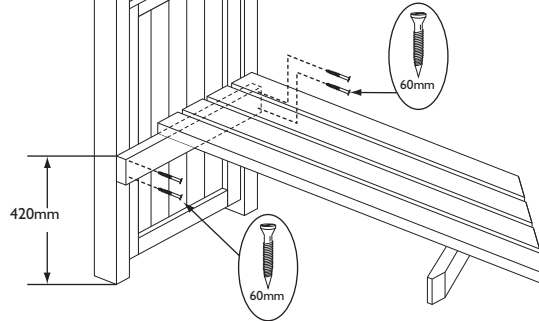

2. Back rest to uprights

Drill 2 holes in the two back rest bearers as shown. Position the back rest so the bearers sit on the bearers of the seat. Secure the back rest to the leg of the upright using 2 x 60mm screws. Screw through the drilled holes in the back rest into the leg of the upright.



Drill

Drill pilot holes in the back rest bearers for each screw.

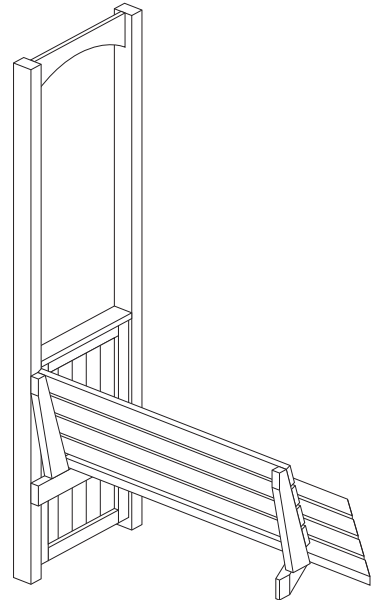
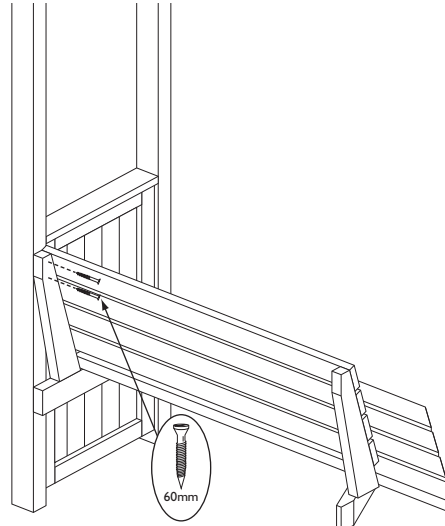
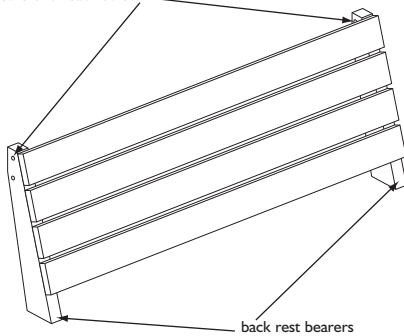

3. Back lattice pane to uprights

Drill pilot holes for the screws in the frame of the back lattice panel as shown. Sit the Back lattice panel on the top of the back rest. Secure to the upright leg using 3 x 60mm screws. Screw through the drilled holes in the lattice into the upright leg.



Drill

Drill pilot holes in the lattice frame for each screw.

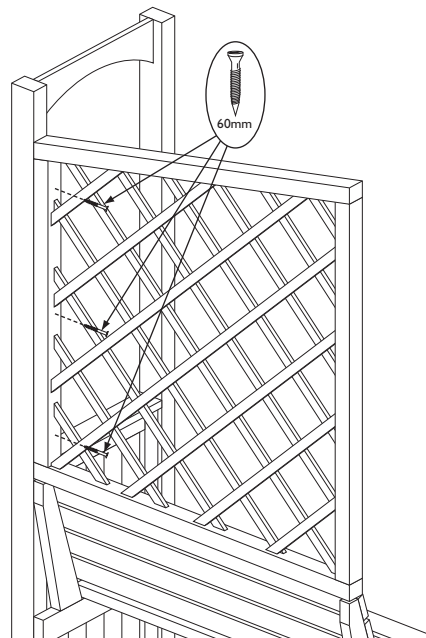
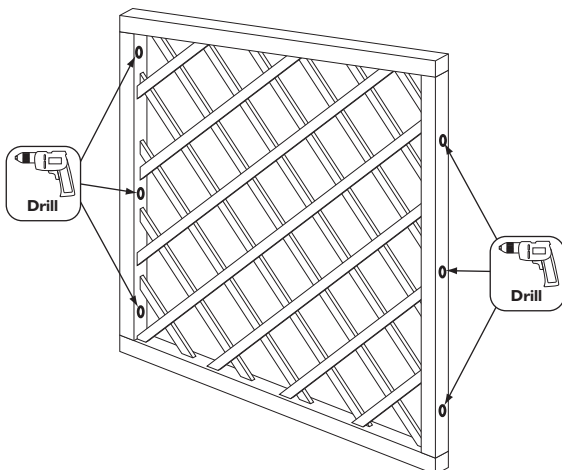

4. Securing the back legs

On a back leg measure and mark the seat height to the same height as on the upright panels (420mm). To the narrow edge of the post secure the seat using 2 x 60mm screws, screw through the drilled holes in the seat bearer into the post. Secure the seat back to the post through the drilled holes in the seat back bearers using 2 x 60mm screws and then attach the lattice using 3 x 60mm screws. Once complete, build the other half in the same way but creating a mirror image as shown.

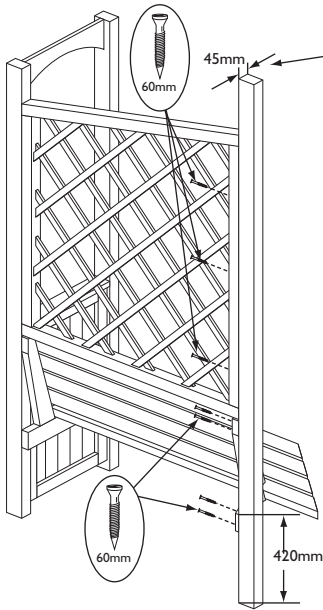

Note:
When attaching the centre posts ensure that it is attached using the narrow edge of the post.

Note:
Once complete, build the other half of the arbour in the same way but creating a mirror image so that you will have 2 sections that look like the picture to the right.

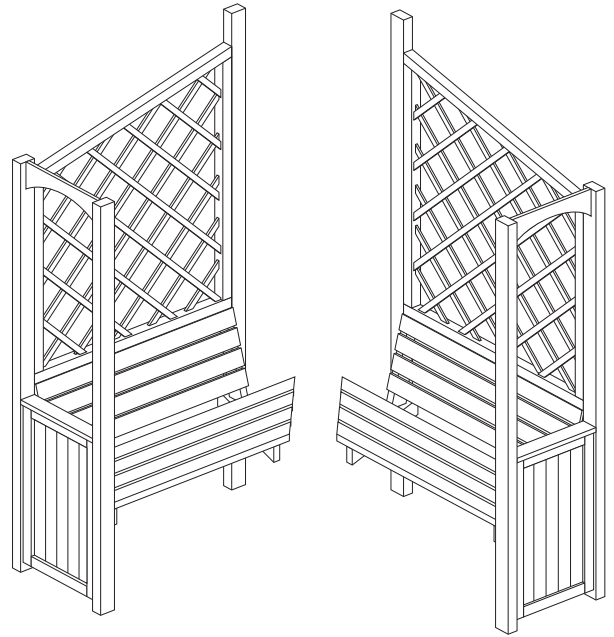

5. corner backrest slats

Drill a hole in each end of the four corner backrest slats. Bring together the two arbour halves and align the ends of the seat slats. Starting with the shortest (350mm) corner backrest slat attach to the ends of the bottom seat back slats of the two sections using 1 x 60mm screw at each end. Attach the next corner backrest slat (380mm) to the second seat back slat up using 1 x 60mm screw at each end, continue adding the remaining two slats in the same way.

Drill pilot holes in each end of the 4 centre seat back slats.

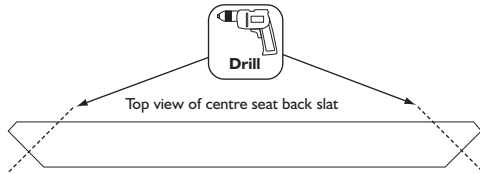

Note:
Secure the centre slats by screwing through the drill hole in the slat into the ends of the seat back slats of the left and right seat backs.

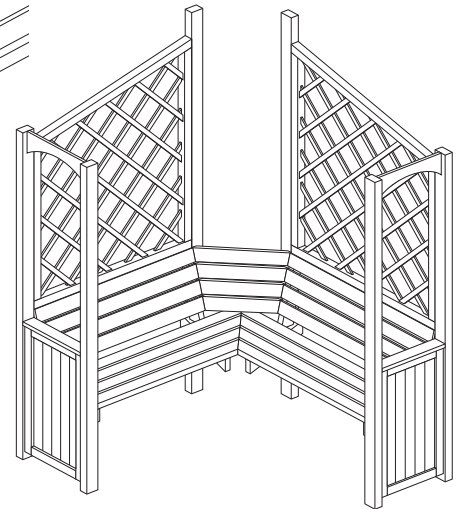
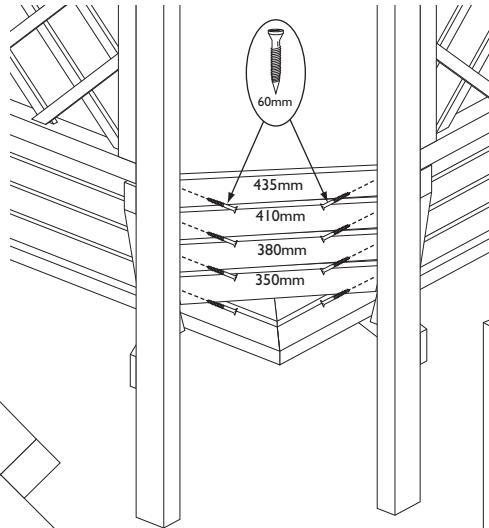
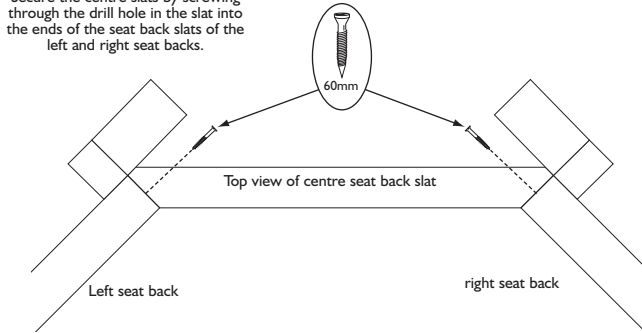

6. Centre seat support

Drill pilot hole in the centre seat support as shown. Position the centre seat support between the two seat sections and secure to the seat bearers using 4 x 70mm screws. Screw through the drilled holes into the seat slat bearers.



Drill pilot holes in the centre seat support for each screw.

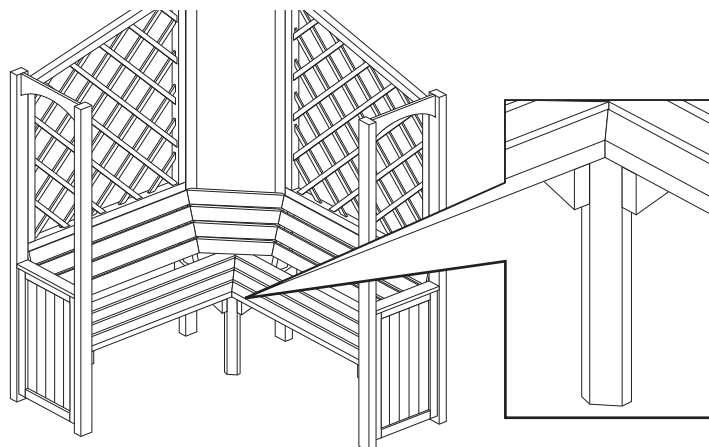
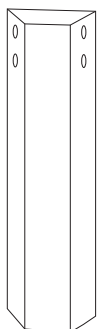
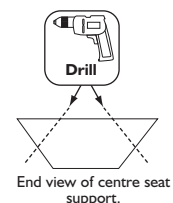

View from back of centre seat support and seat bearers.

Note:
Screw through the drilled holes into the seat slat bearer.

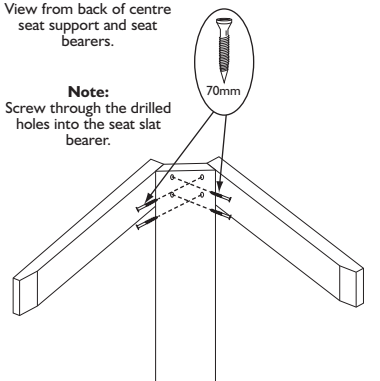

7. Corner lattice

Drill pilot holes in the frame of the corner lattice as shown. Position the corner lattice between the centre posts on top of the corner seat back slats. Secure to the posts using 4 x 60mm screws. Screw through the framing of the lattice into the posts.

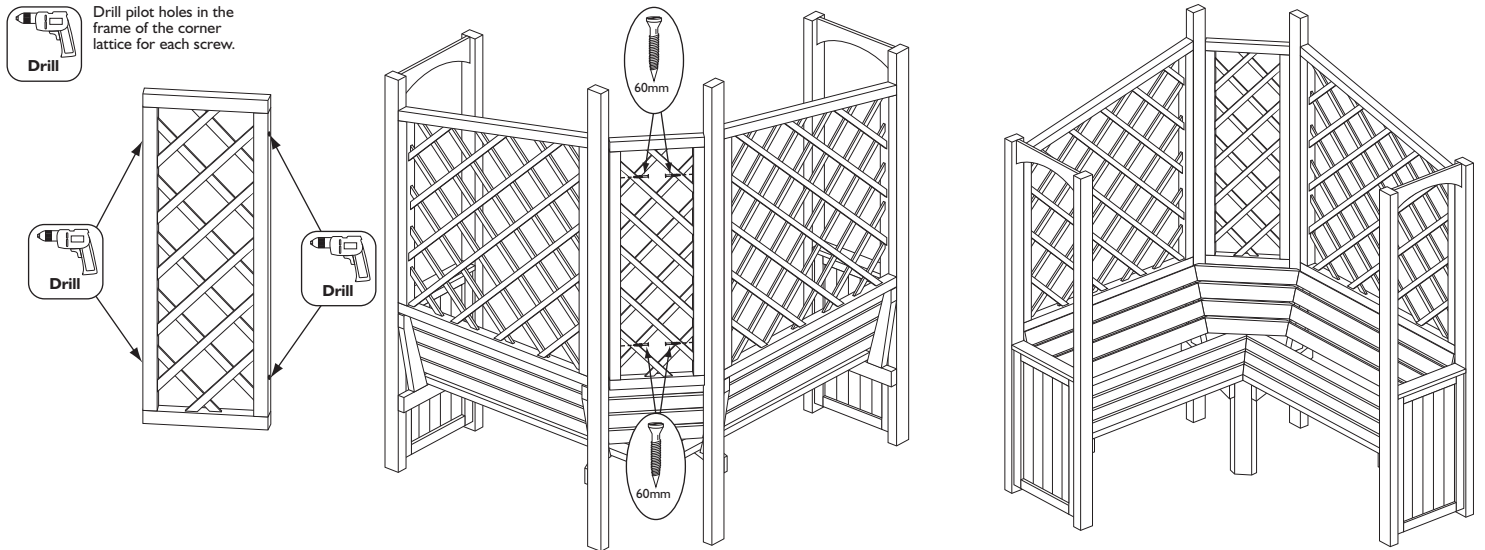

8. Roof rafters

Position the outer rafters as shown. Secure to the back posts using 2 x 100mm screw per rafter. Screw through the post into the end of the rafter and secure to the upright leg using 1 x 70mm screw per rafter. Position the inner rafters as shown and secure through the side of each rafter to the back posts using 2 x 70mm screw per rafter. Secure the other end of the rafter to the upright leg in the same way as the outer rafters.

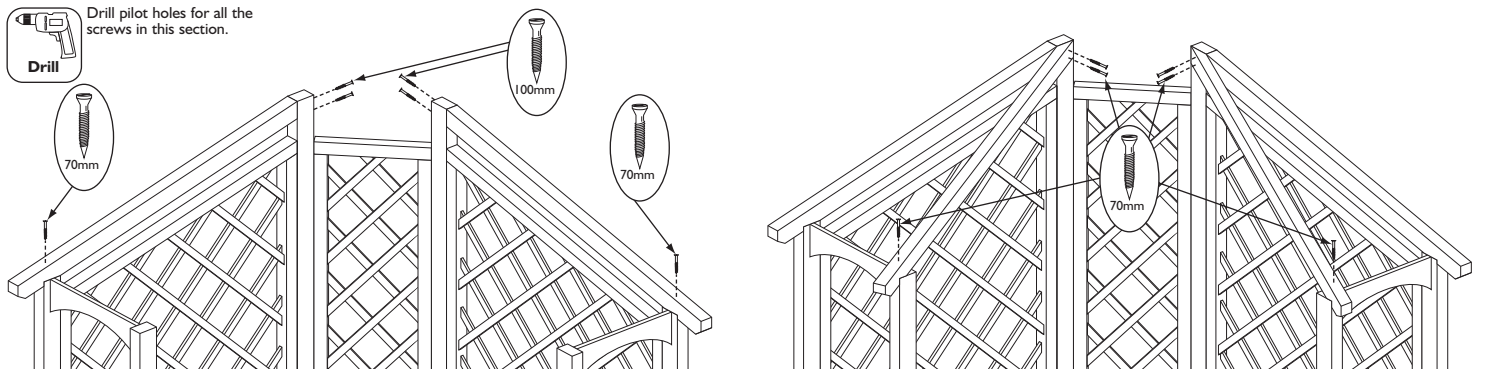

9. Roof panels

Position the left-hand roof panel between the two left-hand rafters, ensure it is pushed fully into the point and secure using 6 x 40mm screws. Screw through the roof panel slat bearers into the roof rafters. Repeat for the right-hand roof panel in between the two right-hand rafters. Position the top centre roof section between the two centre rafters, ensure it is pushed fully into the point and secure using 4 x 40mm screws. Screw through the roof panel slat bearers into the roof rafters. Position the bottom centre roof section between the centre roof rafters, with it pushed up against the top section secure using 4 x 40mm screws.

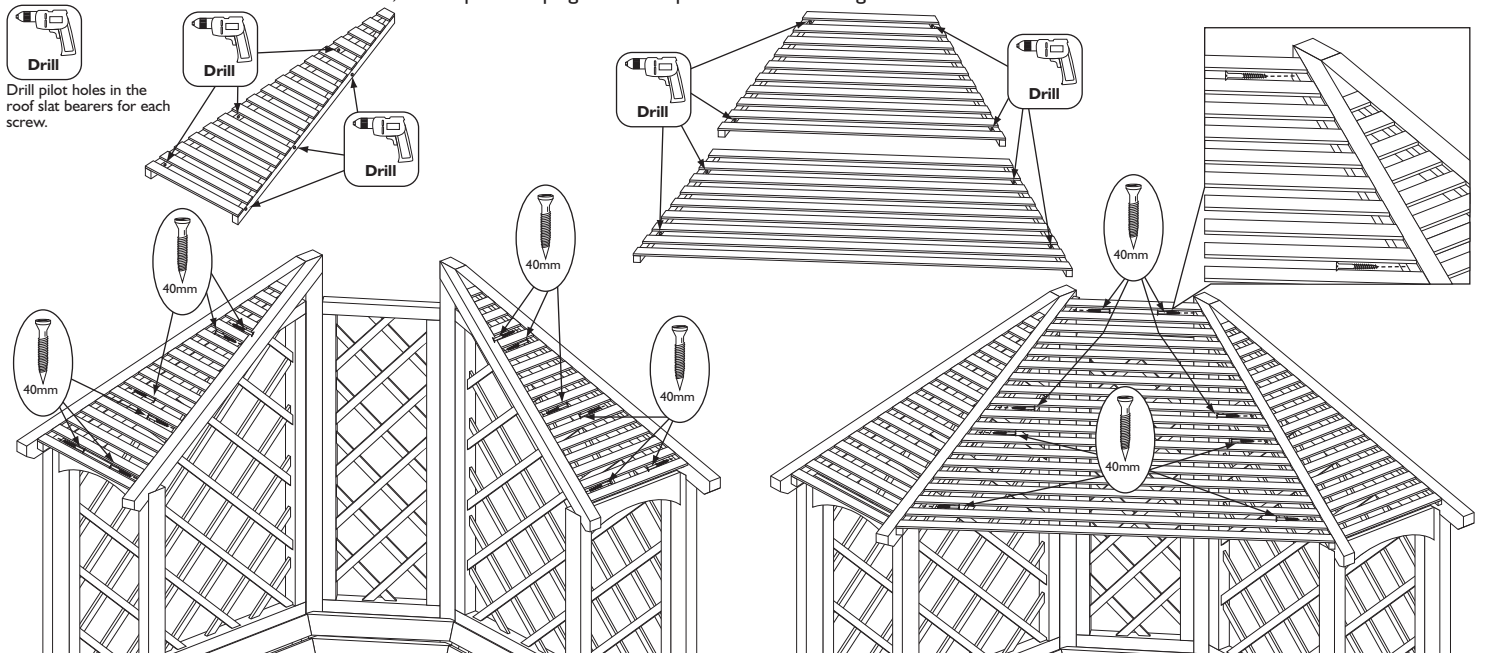

If in doubt of any aspect regarding the assembly, use or safety of your arbour please contact us :

Help Line (Normal Office Hours) 01829 261121

ROWLINSON GARDEN PRODUCTS LIMITED
Unit 2 Green Lane
Wardle Nr.Nantwich
Cheshire
CW5 6BN

We constantly improve the quality of our products, occasionally the components may differ from the components shown and are only correct at time of printing. We reserve the right to change the specification of our products without prior notice.

2006 © Rowlinson Garden Products Ltd